

# NOSHIELD

## Input and output combi filter

# FN 5100

- Long cable feeds up to 600m
- Multiple motors running in parallel
- Retrofit of drives in installations using unshielded cables
- Increased lifespan of motors
- Für lange Motorkabel bis 600m
- Parallelschaltung mehrerer Motoren an einem Umrichter
- Nachrüstung geregelter Antriebe in vorhandenen ungeschirmten Kabelinstallationen
- Erhöhung der Lebensdauer von Motoren
- Grandes longueurs de câbles d'alimentation (jusque 600m)
- Fonctionnement de plusieurs moteurs en parallèle
- Mise à niveau de variateurs dans des installations avec câbles non blindés
- Augmentation de la durée de vie des moteurs



### Technical specifications

Max. operating voltage $U_N$ :	3 x 480/275VAC
Overload:	1,4 x $I_N$ for 1 min. every 15 min.
Derating:	for $T_{amb} > 50^\circ\text{C}$ : $I_N(T) = I_N @ 50^\circ\text{C} \sqrt{((100 - T) / 50)}$
Switching frequency:	$f_{min} = 3\text{kHz}$ to $f_{max} = 16\text{kHz}$
Motor frequency:	0 to 100Hz (higher frequencies after consultation)
dv/dt limitation:	typical ~ factor 6
Max. overshoot:	typical 1300V
Test voltage (input section):	L → PE 2700VDC 2s L → L 2100VDC 2s
Test voltage (output section):	U,V,W → PE 2000VAC 2s U → V, V → W, W → U 1500VAC 2s
Temperature range:	-25°C to +100°C
Climatic class per IEC 68:	25/100/21
Flammability:	minimum UL 94V2
Electrical connections:	touch-safe terminals
Max. cable length:	600m unshielded @ 6kHz switching frequency 200m shielded @ 6kHz switching frequency

### Approvals

		FN 5100-6-45	FN 5100-10-47	FN 5100-16-47	FN 5100-25-47	FN 5100-40-47	FN 5100-63-52	FN 5100-100-35
Filter modules	$I_N$ Output [A]	6	10	16	25	40	63	100
	$P_{inverter}$ [kW]	2.2	4	7.5	11.0	18.5	30	46
	Weight [kg]	3.5	5.3	6.4	10	15	25.5	34

### Maximum motor cable lengths under various operating conditions:

The switching frequency as well as the motor cable length determine the resulting power losses inside the filter. The following table shows the various operating conditions when using one single motor.

Noshield filters FN5100 are specified for:	Ambient temperature °C	Switching frequency kHz	Motor frequency Hz	Cable length $L_{admissible}$
Examples for application combinations:	50	6	50	600m unshielded
	50	6	50	200m shielded
	40	12	50	600m unshielded
	40	12	50	200m shielded
	40	6	100	600m unshielded
	40	6	100	200m shielded
	50	16	100	200m unshielded
	50	16	100	50m shielded

## Drives running in parallel

The maximum admissible cable length for motors running in parallel is as follows

$$L_{\text{admissible}} = \Sigma L_{\text{overall length of all cables}} \times \sqrt{\text{Number of drives}}$$

## Examples of measurements

The following measurements show the effects of using the output filter with shielded and unshielded cable.

The switching frequency of the inverter is 14kHz, the motor frequency is 50Hz, the motor cable length is 100 m and the frequency range is 150kHz - 30MHz:

### Levels on the motorcable measured with a common mode current probe

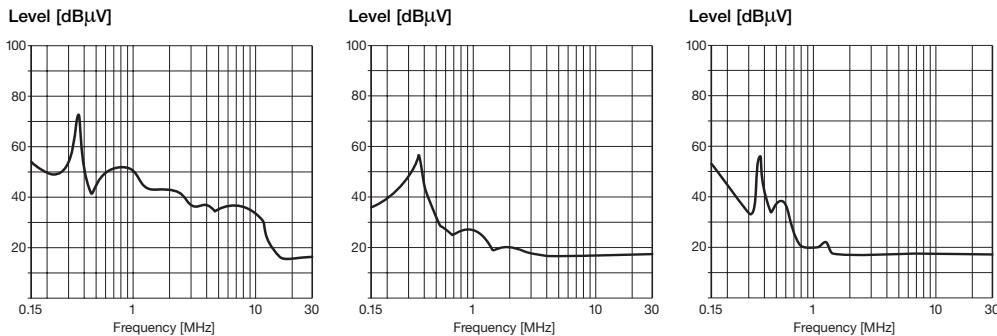

#### Unshielded cable without output-filter section

High interference levels exist in the frequency range up to 15MHz. Other devices within this sphere may be interfered with.

#### Shielded cable without output-filter section

The recommended shielded cable shows good high frequency characteristics. The peak value around 370kHz is dependent on the motorcable length (system resonance).

#### Unshielded cable with output-filter section

About the same interference level as with a shielded cable can be achieved by using the Noshield-filter FN 5100.

### The FN 5100 – series offers the following advantages:

The well tuned combination of line and output filter prevents resonances on the line side even with long cables, ensuring compliance with the conducted emission limits.

Compliance with limits without shielded cables is possible.

With this filter an equal level of interference emissions can be achieved in installations using unshielded cables, as installations using shielded cables without an output filter.

The use of FN 5100 Noshield filters with shielded cables will also significantly increase the immunity of installations.

Dv/dt values as well as the maximum output voltage level of the inverter will be reduced.

This combination requires less space and reduces installation costs.

### Vorteile und Nutzen der Serie FN 5100

Durch die abgestimmte Kombination von Netz- und Ausgangsfilter entstehen auf der Netzseite auch bei langen Kabeln keine Resonanzen d.h. keine Überschreitungen der Störspannungsgrenzwerte.

Möglichkeit unter Einhaltung der Grenzwerte auf geschirmte Leitungen zu verzichten. Mit diesem Filter wird in Anlagen mit ungeschirmten Kabeln ein gleichwertiger Pegel der Störemission erreicht wie mit geschirmten Kabel ohne Ausgangsfilter.

Bei Verwendung des Noshieldfilters FN 5100 mit geschirmten Leitungen wird die Störfestigkeit von Anlagen wesentlich erhöht.

Sowohl du/dt Werte als auch die max. Höhe der Ausgangsspannung des Umrichters werden reduziert.

Die Kombination ermöglicht einen platzsparenden Einbau und reduziert die Montagekosten.

### Série FN 5100 – Avantages :

La combinaison correcte des filtres de ligne et de sortie empêche les phénomènes de résonance du côté ligne, même avec de longs câbles, et garantit la conformité avec les limites d'émissions par conduction.

Cette conformité est possible à réaliser sans câbles blindés.

Avec ce filtre, il est possible d'obtenir un niveau égal d'émission de parasites dans des installations utilisant des câbles non blindés, ou des câbles blindés sans filtre de sortie.

L'utilisation du filtre FN 5100 Noshield avec des câbles blindés augmente aussi notablement l'immunité des installations.

Les valeurs dV/dt ainsi que la tension maximale de sortie du convertisseur sont réduites.

Cette combinaison diminue l'encombrement et les coûts d'installation.

**Mechanical data**

	FN 5100 -6-45	FN 5100 -10-47	FN 5100 -16-47	FN 5100 -25-47	FN 5100 -40-47	FN 5100 -63-52	FN 5100 -100-35	Tol.* mm
<b>A</b>	220	270		260	300	345	395	± 1.5
<b>B</b>	70	100		115		135	175	± 1.0
<b>C</b>	240	260		365		465 ± 2.0	565 ± 2.0	± 1.5
<b>D</b>	200	220		305		405 ± 2.0	505 ± 2.0	± 1.5
<b>E</b>	190	240		230	270	315	365	± 0.5
<b>F</b>	40	70		80		100	140	± 0.3
<b>G</b>	225 ± 0.5	245 ± 0.5		350		450	550	± 0.8
<b>H</b>	5.5 ± 0.1			7				± 0.2
<b>J</b>	10			13				± 0.2
<b>K</b>	M5			M6			M10	-
<b>L</b>	2.5	3						± 0.1
<b>M</b>	400		500		700			± 15
<b>N</b>	500		600		800			± 15
<b>O</b>	AWG 14		AWG 12	AWG 10	AWG 8	AWG 4	AWG 2	-
<b>P</b>	solid wire 6mm <sup>2</sup> wire† AWG 12 wire† 4mm <sup>2</sup> max. 0.5 Nm		solid wire 16mm <sup>2</sup> wire† AWG 6 wire† 10mm <sup>2</sup> max. 2.0 Nm			solid wire 25mm <sup>2</sup> wire† AWG 4 wire† 16mm <sup>2</sup> max. 2.2 Nm	solid wire 50mm <sup>2</sup> wire† AWG 1/0 wire† 50mm <sup>2</sup> max. 8.0 Nm	

† Insulated wire (cable)

\* Measurements share this common tolerance unless otherwise stated.

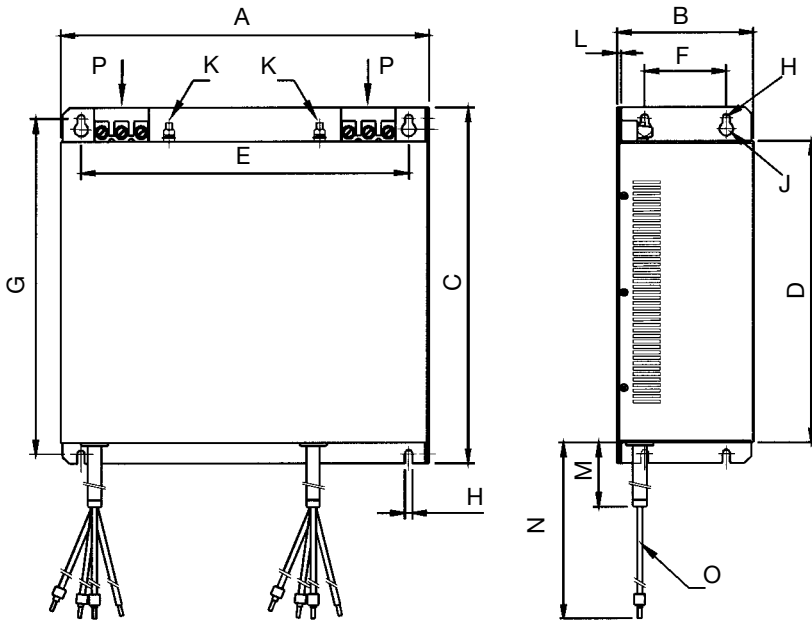

All dimensions in mm; 1 inch = 25.4mm

**Electrical schematic**

The FN 5100 has been developed to both reduce the emissions and increase the immunity of installations.

